

SUBMITTAL DATA

HYDRO MAXX

MODEL NO RDP AUTOMATIC ROUND DAMPER WITH MP12M PLUG-IN MOTOR

JOB NAME: **LOCATION:** **DATE:**
PURCHASER: **ENGINEER:**
SUBMITTED TO: **FOR:** **REVIEW ()** **APPROVAL ()**

The RDP series are galvanized steel, single blade dampers compete with a 12 Volt DC motor actuator. These dampers are shipped complete and ready for installation. The RDP can be installed in any position in any properly sized duct. All RDP dampers are rated for duct systems less than 2.0" W.C.

Dampers are available in 4", 5", 6", 7", 8", 9", 10", 12", 14", 16", 18" and 20" diameters. Dampers are ordered as RDPdd, using 2 digits for each dimension.

A 12 Volt DC damper motor, Model MP12M, powers the RDP. The motor powers the damper closed and open. The MP12M motor wires by simply plugging the motor in using the modular cord, supplied with each damper. The modular cord is a 25' length of standard four (4) conductor telephone wire with RJ11 jacks on each end. The motor is complete with 2 jacks allowing you to daisy chain up to 10 dampers per zone. The MP12M motor has been tested to over 1,000,000 cycles to provide long life. Even replacing the motor is a simple less than one (1) minute change by loosening the setscrew holding the motor onto the damper, slide the motor off the damper shaft, place a new one on and secure with the screw. The RDP motor also has a two-color Light Emitting Diode (LED) to indicate the damper position. When the LED is GREEN the damper is Open. When the LED is RED the damper is Closed. When the LED is not lit the motor is typically moving between open and closed. The motor cycles between open and closed in less than 5 seconds

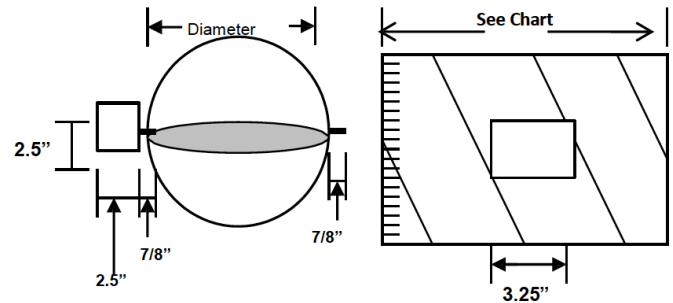

Specifications

Construction - 24 Ga. Galvanized Steel (4" - 8")
22 Ga. Galvanized Steel (9" - 20")

Linkage - Direct Drive

Sizes - 4", 5", 6", 7", 8", 9", 10", 12", 14", 16", 18", 20"

Motor Voltage - 12VDC, 0.100A

Torque - 7.0 in/lbs, 112.0/oz, 0.79NM

Temperature Rating: 0°F to 150°F Operating,
-13°F to 175°F Storage

Humidity - 5% to 95% Non-Condensing

Damper Timing - Nominal 5 Sec. Powered Open-Closed

Connection - Modulat RJ11, 2 Ports

Duct Pressure - Maximum 2" W.C.

All dimensions are nominal. Dampers 10" diameter and less are 9.75" in length. Dampers 12" and over are .250" shorter in length than the diameter.

Installation

The RDP is used in-line with the duct and can be installed on a take-off or in-line at any point in the duct. It is recommended the damper be installed as close to the air handler as practical.

Place the flat collar end of the damper over the crimped end of the take-off or rigid metal duct. Insert crimped end of round damper into un-crimped end of rigid round duct and secure with sheet metal screws. When using flexible duct, slip duct over end of the round damper and secure with duct straps (not provided).

The drawing to the right shows a top view of the damper in line of the duct. When mounting, it is recommended that the motor and blade shaft be horizontal to the ground.

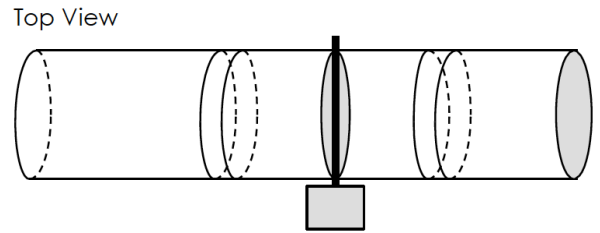

Round damper in-line with round duct.

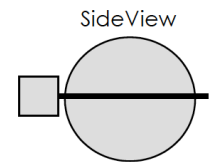

Minimum Position Adjustment

Simply open the cover to minimum position setting. With a screwdriver, loosen the setscrew and adjust your setting to desired position.

Checkout

To checkout the operation of the dampers the control panel needs to be operating. It is recommended that each damper be checked before installing into the duct.

To check the damper, plug the damper into a zone on the control panel. Each zone of the panel has an LED that will be Green when the damper is to be open. When the panel LED is off, the damper will close and the damper LED will turn RED.

All dampers are 100% factory tested with the cord provided with each damper.



OPEN



CLOSED

The damper shaft is square however the motor has a small triangular shape that also indicates the position of the damper. If the LED does not light, this will indicate the damper is either opening or closing. The damper may be closed and the LED not lit Red as the damper may have stopped short of full closed due to roundness of the damper.

Troubleshooting

If the damper LED does not light and the motor is not moving when plugged into the control panel, unplug and retry plugging in again. Until the motor moves and the LED lights. Make sure the cord is not pinched or broken.

The motor is powered by 12VDC from the panel. Check the connector on the panel for 12VDC as shown below.

